

CHILLER – FREEZER THERMOSTAT

Model RN5+ (COMPATIBLE WITH RN2 / RN3 / RN4 / RN4+ / RN5)



KIOUR

Firmware V4.2.0

ATTENTION

Read carefully these instructions before installing and using this device and keep them for future reference. Attention to installation and electrical wiring. Use this device only as described in this document and never use itself as a security device. Disconnect the power supply before performing any type of maintenance operation. Do not expose the device to liquid leakage, high temperatures over +55°C, high humidity over 80%. The device must be disposed of in accordance with local standards for the collection of electrical and electronic equipment.



DESCRIPTION

RN5+ is a thermostat for chiller or freezer cabinet, without plastic enclosure, suitable for all applications including the ones with anti-explosive standards and has the following specifications: room and evaporator temperature is controlled with NTC / PTC sensors; 3 indication digits with resolution 0.5°C and 5 buttons; one serial input for controlling the cabinet's door; 5 relays: compressor 30A 250VAC, fan 10A 250VAC, deFrost 10A 250VAC, lamp 10A 250VAC and door resistance in chillers or drainage resistance in freezers 10A 250VAC; defrosting may be electric or by hot gas; a buzzer in case of an alarm; a serial data port in order to connect either to cloud IoT platform Cortex via a mobile application or to a computer via CAMIN software for full monitoring and data logging of the device (see page 2 – Serial input of the thermostat). The device is mounted through panel hole and secured by screws.

THERMOSTAT'S DIMENSIONS

ATTENTION: Read carefully the technical specifications and make sure that the working conditions are appropriate. According to safety standards, the device must be fastened in such a way that it cannot be removed without the use of tools.

Dimensions are in mm. The device is mounted through panel hole and secured by 3 screws (Φ=3mm).

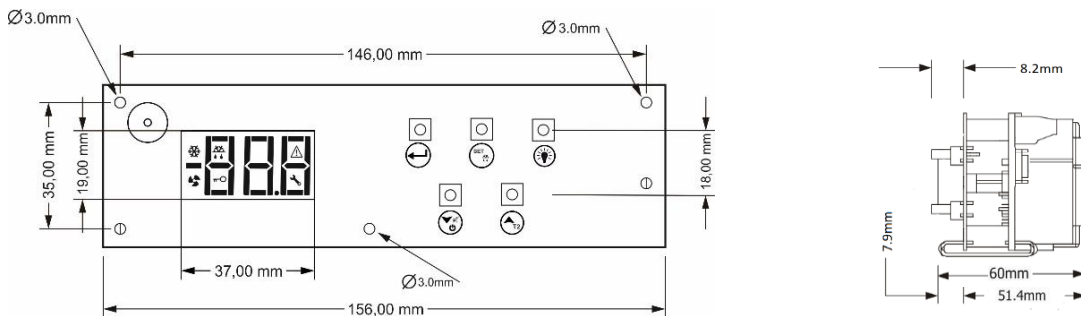

INDICATIONS AND BUTTONS FUNCTION

Display indications	
	compressor ON
dFr 	deFrost ON
	fan ON
	alarm ON
Loc 	keyboard locked
	malfunction ON
---	evaporator's sensor is deactivated

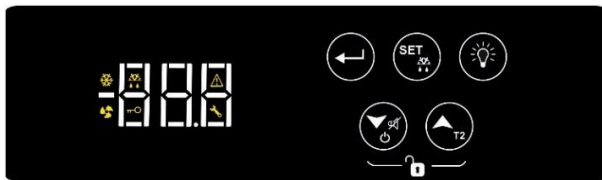

Keyboard	
	enter/exit the parameter's menu confirm new value of a parameter
	display the parameter's value manual deFrost
	ON/OFF lamp
	down arrow mute buzzer ON/OFF cabinet
	up arrow display the evaporator temperature T2 (and the room temperature if Set Point is constantly displayed)

For more indications regarding the alarms please see the alarm's table at page 6.









UNLOCKING THE THERMOSTAT

By pressing at the same time for 3 seconds, the countdown starts and the keyboard unlocks while the yellow small key on the display turns off. Instantly the temperature measurement unit °C/°F is displayed. The keyboard locks automatically after 60 seconds of inertia.

ADJUSTING ROOM'S TEMPERATURE – SET POINT

1. Unlock the keyboard by pressing at the same time and the countdown starts for 3 seconds.
2. Press to display the first parameter **SPo**.
3. Press to display its value. With or change its value.
4. Press to save the new value. The cabinet is working properly with the new adjustment.

INDUSTRIAL FACTORY SETTINGS OF CABINET

1. Choose from the following table the corresponding program of your cabinet.
2. Unlock the keyboard by pressing at the same time   and the countdown starts for 3 seconds.
3. Press  to display the first parameter **SPo**. Press 4 times  and the parameter **Cod** is displayed.
4. Press  to display its value and press  to enter the cabinet's program. Press  to store the cabinet's program to parameter **Cod**.
5. Press  again to exit the parameter menu. The indication "YES" is displayed and all appropriate settings are now stored.
6. Toggle cabinet's power supply in order to work properly and based on the registered settings.

Cabinet's model	Program
Upright chiller with freon R134a	33
Upright chiller with propane R290	38
Upright freezer with stainless door with freon R404A	36
Upright freezer with stainless door with propane R290	34
Upright freezer with glass door with freon R404A	37
Upright freezer with glass door with propane R290	35
Freezer counters	39
Refrigerated counters	31
Saladette	32

CAUTION!

When the temperature probe is PTC, parameter 27 must be changed to **SEn = 0**



PTC probes are as shown in the image:





ON / OFF CABINET

1. To activate the cabinet, press for 3 seconds .
2. To deactivate the cabinet, unlock the keyboard by pressing at the same time   and the countdown starts for 3 seconds. Press for 3 seconds .

CABINET'S LIGHT



1. If the cabinet has a light, the lamp turns on when the door is open and turns off once the door closes. Press and hold the button  to turn ON the lamp bypassing the door control. Press again the button , the lamp turns off and operates based on the door switch. As long as the door is open, the lamp button is deactivated.

MANUAL DEFROST

1. Unlock the keyboard by pressing at the same time   and the countdown starts for 3 seconds.
2. Press for 3 seconds  to start a manual defrost with duration based on the parameter **dd2** (table page 3).











For more information regarding the defrost check the description of parameter **dt6** (table at page 4 - parameter No 11).

INDICATION OF THE EVAPORATOR'S TEMPERATURE T2 (AND ROOM'S TEMPERATURE WHEN THE SET POINT IS CONSTANTLY DISPLAYED)

1. Unlock the keyboard by pressing at the same time   and the countdown starts for 3 seconds.
2. Press and hold  to display the evaporator's temperature for 2 seconds and then the cabinet's temperature (if parameter **diP** is adjusted to constantly display the Set Point and not the room's temperature).
3. If the evaporator's temperature is deactivated from the parameter **OS2**, it is displayed "-.-".

PROGRAMMING A PARAMETER

ATTENTION: to gain full access to the parameter's menu, the 5th parameter **Cod** must be adjusted to **22** (see parameter table page 4).

1. Unlock the keyboard by pressing at the same time   and the countdown starts for 3 seconds.
2. Press  to enter the parameter menu.
3. Choose the parameter you want to adjust by pressing  or  and press  to display its value.
4. Press  or  to change its value and then press  to store the new value.
Press  if you want to cancel the new value and the parameter's name is displayed.
5. Press  to exit the parameter menu.

TECHNICAL SPECIFICATIONS OF THE THERMOSTAT

Model **RN+** power supply: 230VAC ±10% 50/60Hz / Maximum power consumption: 3W. Model **RNW+** switching power supply 100-264VAC 50/60Hz 5W

It is recommended using a power supply safety fuse: 0.5A (not included)

Room and evaporator temperature sensors NTC 10K 1% 25°C IP68 with rubber tube and temperature range -50÷+112°C (-58÷+230°F) or PTC 1K 25°C with metal tube and temperature range -50÷+150°C (-58÷+302°F) / Accuracy: ±0.5°C

Alarm buzzer / Serial input with 5pin connector / Digital input door

5 anti-explosive relays: compressor relay 30A res. 250VAC normally open contact / fan relay 10A res. normally open contact / defrost relay 10A res. normally open contact / lamp relay 10A res. normally open contact / door resistance relay or drainage resistance 10A res. normally open contact / Max current load 16A.

Connections: cable cross section 2.5 mm² for all relays / cable cross section from 0.25 to 1.0 mm² for the sensors and door switch /  Use cable with appropriate temperature ratings – terminal block temperature possible rise above 60°C

Connections with terminal blocks 18A using cable with cable cross section up to 2.5 mm² / It is recommended using a torque wrench with maximum torque 0.4Nm

Operating temperature: -15÷+55°C / Storage temperature: -20÷+80°C

No plastic enclosure / Protection IP 00 / Device Class: 2



The device is mounted on appropriate panel holes and secured with 3 screws ($\Phi=3\text{mm}$). The holes are created only for button and display access. An appropriate membrane with protection IP65 must be placed over the panel to secure the device from liquid leakage and human interference.

Firmware: V4.2.0

SERIAL INPUT OF THE THERMOSTAT

RN5+ connects via serial input to cloud IoT and the online CORTEX platform or to a local computer with the CAMIN program or to any Modbus network.

- Mobile application for android and iOS, Cloud service and CORTEX platform: connection to the cloud and the CORTEX platform for monitoring - recording and managing the thermostat from your mobile, tablet or any computer, email and mobile notifications in case of an alarm.
- CAMIN program: local connection and monitoring - recording and management of the thermostat through the CAMIN program installed on a local computer.

ELECTRICAL DIAGRAM OF THE THERMOSTAT

ATTENTION: according to safety standards, the device must be properly positioned and protected from any contact with electrical parts. The device must be fastened in such a way that it cannot be removed without the use of tools. Disconnect the main safety switch of the installation before proceeding to any maintenance. Disconnect the power supply of the device before proceeding to any maintenance. Do not place the device near heat sources, equipment containing strong magnets, in areas affected by direct sunlight or rain. Prevent electrostatic discharges and sharp objects from being inserted to the device. Separate signal cables from power supply cables to prevent electromagnetic disorders. Signal cables must never be in the same pipe with the power supply cables.

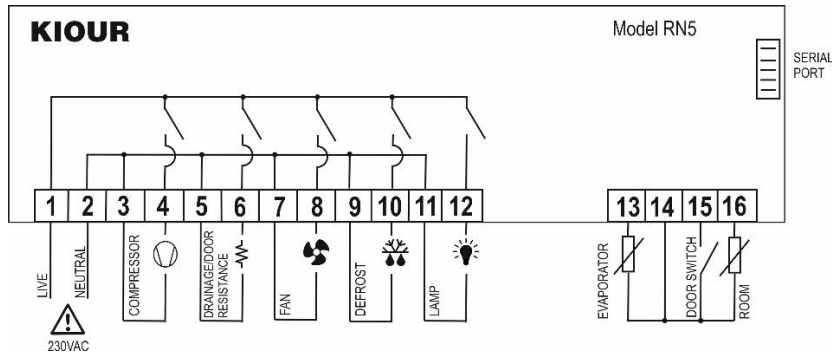

ELECTRICAL DIAGRAM OF THE CABINET

ATTENTION: according to safety standards, the device must be properly positioned and protected from any contact with electrical parts. The device must be fastened in such a way that it cannot be removed without the use of tools. Disconnect the main safety switch of the installation before proceeding to any maintenance. Disconnect the power supply of the device before proceeding to any maintenance. Do not place the device near heat sources, equipment containing strong magnets, in areas affected by direct sunlight or rain. Prevent electrostatic discharges and sharp objects from being inserted to the device. Separate signal cables from power supply cables to prevent electromagnetic disorders. Signal cables must never be in the same pipe with the power supply cables.



Refrigerated counters

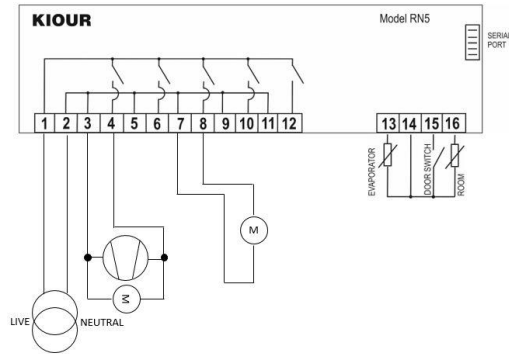

Saladette / Counter with glass door

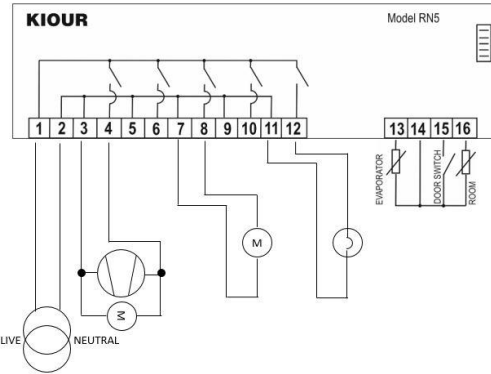

Upright freezer with stainless door

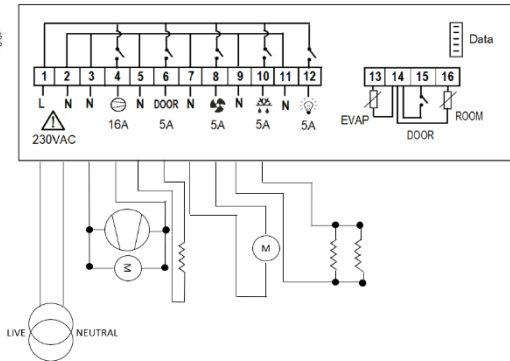

Upright chiller

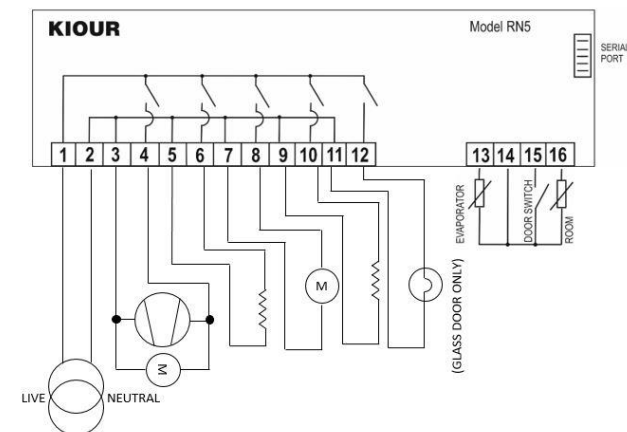



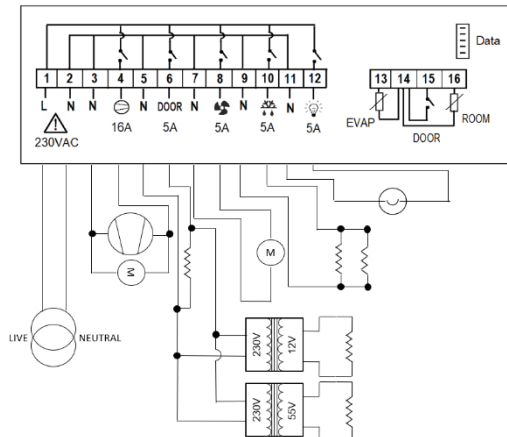

Upright freezer with glass door



PARAMETER'S TABLE

No	code	description	min	max	M.M.	INDUSTRIAL FACTORY SETTINGS OF THE CABINET									
						Upright chiller R134a	Upright chiller R290	Upright freezer with stainless door R404A	Upright freezer with stainless door R290	Upright freezer with glass door R404A	Upright freezer with glass door R290	Freezer counters	Refrigerated counters	Saladette	
						Program 33	Program 38	Program 36	Program 34	Program 37	Program 35	Program 39	Program 31	Program 32	
1	SPo	SET POINT: room temperature setting	LSP	HSP	°C/°F	0.0	0.0	-20.0	-22.0	-18.0	-18.0	-20.0	0.0	3.0	
2	ALo	Low alarm room threshold	-50.0	150	°C/°F	-5.0	-5.0	-25.0	-25.0	-22.0	-22.0	-25.0	-5.0	-5.0	
3	AHi	High alarm room threshold	-50.0	150	°C/°F	15.0	15.0	0.0	0.0	0.0	0.0	0.0	15.0	15.0	
4	dr1	Time between two successive defrost	1	100	hours	4	4	5	7	5	7	3	4	4	
5	Cod	Access code to the following parameters Cod = 22.	0	255	-	22	22	22	22	22	22	22	22	22	
6	diF	Differential of room temperature SPo (thermostat delay)	0.1	25.5	°C/°F	3.0	3.0	3.0	4.0	3.0	4.0	2.0	3.0	3.0	
7	dd2	<i>Defrost duration</i> (manual and automatic), where 0 = defrost is deactivated.	0	120	min	20	20	35	35	35	35	30	25	25	
8	dP3	Dripping timer, where the compressor is OFF after defrost	0	15	min	2	2	5	5	5	5	3	0	0	
9	dY4	<i>Display indication during defrost</i> -02 = indication SPo+diF when room's temperature is greater than SPo+diF -01 = indication dFr when room's temperature is greater than SPo+diF 0 = indication of room's temperature 1 to 40 min = indication dFr from 1 to 40 min counting from the beginning of defrost	-02	40	min	25	25	35	35	35	35	15	25	25	
10	dE5	<i>Defrost end temperature with the evaporator's temperature sensor activated</i> Automatic and manual defrost does not start if the evaporator temperature is greater than the defrost end temperature dE5. In case of evaporator's sensor malfunction (LF2), there is no check of defrost end temperature and defrosting is completed after time adjusted in parameter dd2 elapses. <i>with the evaporator's temperature sensor deactivated</i> Defrost end temperature is the room temperature. Automatic defrost does not start if the evaporator temperature is greater than the defrost end temperature dE5. Manual defrost starts regardless of the room's temperature and ends after time adjusted in parameter dd2 elapses.	0.0	100	°C/°F	20.0	20.0	30.0	30.0	30.0	30.0	8.0	20.0	20.0	
11	dt6	<i>Type of defrost</i> 0 = electrical (compressor OFF, resistance ON), if SPo is smaller or equal than -0.1°C defrost occurs using the resistance based on time adjusted from the parameter dd2, if SPo is greater or equal than 0°C defrost occurs using the fan based on time adjusted from the parameter dd2. 1 = hot gas (compressor ON, resistance ON) ----- <i>Defrost with the evaporator's temperature sensor activated</i> Automatic or manual defrost ends either with time adjusted from the parameter dd2 or with defrost end temperature dE5, whatever comes first. Automatic or manual defrost does not start if the evaporator temperature is greater than the defrost end temperature dE5. <i>Defrost with the evaporator's temperature sensor deactivated</i> Defrost end temperature is the room temperature. Automatic defrost ends either with time adjusted from the parameter dd2, or with defrost end temperature dE5, whatever comes first. Manual defrost starts regardless of the room's temperature and ends after time adjusted in parameter dd2 elapses.	0	1	-	0	0	0	0	0	0	0	1	0	0
12	AF1	<i>Alarm setting</i>	0	1	-	0	0	0	0	0	0	0	0	0	

		<p>0 = automatic deactivation, where the alarm stops once the cause of the alarm disappears. 1 = manual deactivation, where the alarm indication remains even if the cause of the alarm disappears and it's cleared only by pressing .</p> <p>In any case by pressing , the buzzer stops and  turns on to state that the cause of the alarm still exists. Muting the alarm buzzer by pressing  once is valid until all alarms disappear.</p>												
13	At2	<p>Time delay in activating "AHi", "ALo" and the buzzer among them. This setting does not apply to sensor failure and door alarm. -01 = deactivate buzzer 0 = immediate buzzer activation 1 to 120 min = delay in buzzer activation When the cabinet starts for the first time, the buzzer is deactivated until the last alarm disappears.</p>	-01	120	min	25	25	60	60	60	60	60	20	20
14	Fo1	<p>Evaporator's temperature controlling the fan operation during defrost and normal operation (parameter oS2 = 1). If the evaporator's sensor is deactivated, the parameter does not operate. For more information check the parameters Ft2 and Fd3.</p>	-50	100	°C/°F	5.0	5.0	-10.0	-10.0	-10.0	-10.0	-5.0	0.0	0.0
15	Ft2	<p>Evaporator's fan operation -01 = continuous function 0 = parallel with the compressor 1 to 15 min = functions at the same time with the compressor and when the compressor stops, the fan stops after the selected minutes</p>	-01	15	min	0	0	0	0	0	0	-1	-01	-01
16	Fd3	<p>Fan's operation during defrost for SPo smaller or equal than -0.1°C 0 = OFF and starts with the compressor if the evaporator's temperature is smaller than Fo1. During hot-gas, where the compressor is always ON, the fan starts if the evaporator's temperature is smaller than Fo1. This setting applies only with the evaporator's sensor activated. 1 = ON when the evaporator's temperature is smaller than Fo1 – setting applies only with the evaporator's sensor activated 2 = always ON in both types of defrost (electrical / hot gas) regardless of the evaporator's sensor operation</p>	0	2	-	0	0	0	0	0	0	0	2	2
17	Co1	Compressor's minimum time ON	0	15	min	0	0	0	0	0	0	0	0	0
18	CP2	Compressor's minimum time OFF	0	15	min	2	2	2	2	2	2	2	2	2
19	CF3	<p>Compressor's operation in case of room's sensor malfunction -01 = compressor OFF 0 = compressor ON while defrost starts based on timer dr1 and ends based on timer dd2 or temperature dE5, whichever comes first. 1 to 150 min = compressor time ON while defrost starts based on timer dr1 and ends based on timer dd2 or temperature dE5, whichever comes first.</p>	-01	150	min	3	3	3	3	3	3	3	3	3
20	CF4	Compressor time OFF in case of room's sensor malfunction	1	150	min	3	3	3	3	3	3	3	4	4
21	SE1	Room sensor offset	-10.0	15.5	°C/°F	0.0	0.0	1.0	1.0	1.0	1.0	1.0	1.0	1.0
22	SE2	Evaporator sensor offset	-10.0	15.5	°C/°F	0.0	0.0	1.0	1.0	1.0	1.0	1.0	1.0	1.0
23	oS2	<p>Evaporator's sensor operation 0 = deactivated sensor 1 = activated sensor</p> <p>When the sensor is deactivated, by pressing  it is displayed "- - -". During defrost and when the sensor is deactivated, the defrost end temperature dE5 is the room temperature.</p>	0	1	-	1	1	1	1	1	1	1	0	0
24	LSP	Lower setting limit of SPo	-50.0	150	°C/°F	-2.0	-2.0	-21.0	-22.0	-18.0	-18.0	-21.0	0.0	3.0
25	HSP	Maximum setting limit of SPo	-50.0	150	°C/°F	10.0	10.0	-10.0	-10.0	-10.0	-10.0	-10.0	10.0	10.0

26	C_F	Temperature measurement unit: toggling between °C/°F do not adjust automatically parameters regarding temperature, the user must change them manually 0 = °C 1 = °F	0	1	°C/°F	0	0	0	0	0	0	0	0	0
27	SEn	Sensor type NTC/PTC 0 = PTC 1 = NTC	0	1	-	1	1	1	1	1	1	1	1	1
28	trE	Response time of the device on network	20	100	msec	50	50	50	50	50	50	50	50	50
29	Add	Device address on network	0	255	-	1	1	1	1	1	1	1	1	1
30	diP	Display's indication 0 = room temperature indication 1 = SET POINT (SPo) indication unless an alarm appears. The first time that the cabinet turns on, room's temperature is displayed until the cabinet reaches for the first time SPo. Afterwards SPo is constantly displayed regardless of room temperature.	0	1	-	0	0	1	1	1	1	0	0	0
31	Odo	Door switch operation 0 = OFF 1 = NC (normally close) 2 = NO (normally open) If the cabinet's door remains open for 2 minutes, the alarm dor is activated and the compressor stops.	0	2	-	1	1	1	1	1	1	0	0	0
32	Pro	cabinet's program is displayed (industrial factory settings) – the parameter cannot be programmed	-	-	-	33	38	36	34	37	35	39	31	32
33	bAU	Baud rate: 0 = 2400 / 1 = 4800 / 2 = 9600 / 3 = 19200	0	3	-	3	3	3	3	3	3	3	3	3
34	tPE	Product number – not programmable	-	-	-	200	200	200	200	200	200	200	200	200
35	UEr	Firmware version - no access	-	-	-	4.2.X	4.2.X	4.2.X	4.2.X	4.2.X	4.2.X	4.2.X	4.2.X	4.2.X

ALARM'S TABLE		
1	LF1	Room sensor malfunction
2	LF2	Evaporator sensor malfunction
3	ALo	Low room temperature
4	AHi	High room temperature
5	dor	Open door (If the cabinet's door remains open for 2 minutes, the alarm dor is activated and the compressor stops)
6	EEr	error in memory RAM: re-enter the SPo of the cabinet (see ADJUSTING ROOM'S TEMPERATURE – SET POINT page 1)
The alarms are automatically deactivated once the cause of the alarm disappears.		

Made in Greece.



The device is under two year's guarantee. The guarantee is valid only if the manual instructions have been applied. The control and service of the device must be done by an authorized technician. The guarantee covers only the replacement or the service of the device. KIOUR PC implements a Quality Management System according to EN ISO 9001:2015 Standard with registration number 01013192. KIOUR preserves the right to adjust its products without further notice.